

探索未來 2024

木光園市

兒童美術館 開館展

青埔 4/03 - 9/1

八德 4/30 - 9/8

WHERE THE ADVENTURE BEGINS TCAC Inaugural Exhibition

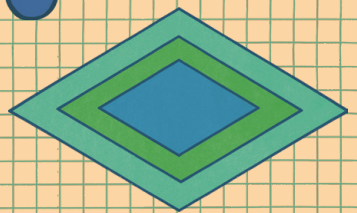
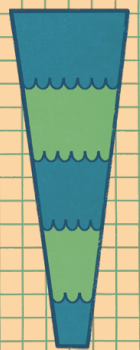
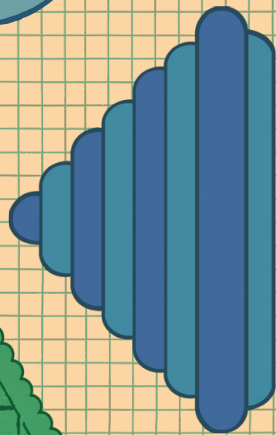
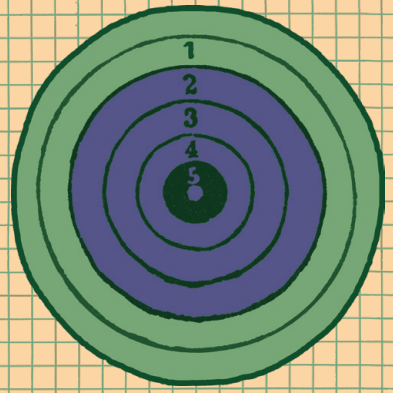
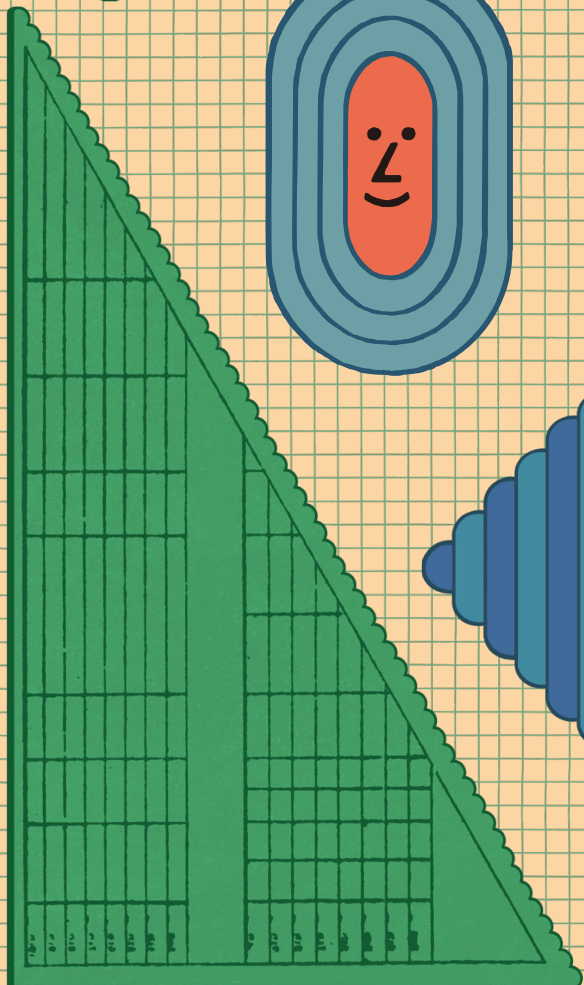
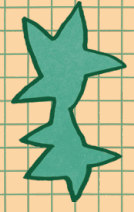
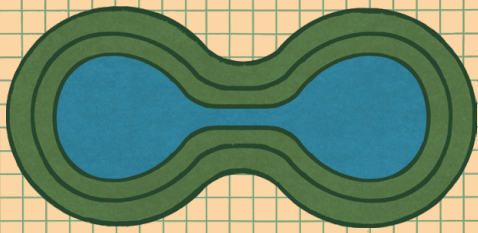
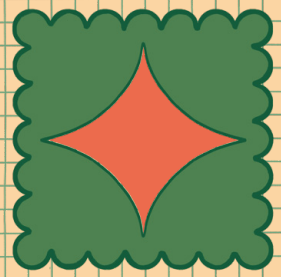
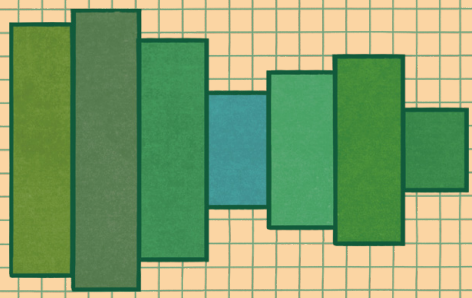

WHERE THE ADVENTURE BEGINS!

Taoyuan Children's Art Center Inaugural Exhibition

We live in a big city where high-speed railways are built, planes are often seen taking off and landing, and where many roads converge. These densely packed pathways, like blood vessels, bring busy people from different places to this city. Suddenly, in the middle of a lovely green space near a pond, a building that looks just like a sandwich or maybe a spaceship pops up. It turns out to be the new Taoyuan Children's Art Center that will make a difference to the City!

What is a Children's Art Center? What can we find inside? How will the city change along with the birth of such an art space? "Where the Adventure Begins! Taoyuan Children's Art Center Inaugural Exhibition" is located in Qingpu, and its parallel exhibition is located in Bade. The exhibition includes four themes: "Container City," "Map City," "Nature City," and "Arrival Cities," inviting 12 artists to create fantastical worlds and challenging tasks. You are invited to roll up your sleeves, observe our city through art, feel and think freely, embark on an exploration and adventure in the Children's Art Center through courage and creativity!



“Where the Adventure Begins!”

Education Promotional Event

With the future being so full of changes and uncertainties, let's take a fresh look at learning together! The inaugural exhibition, “Where the Adventure Begins!” kicks off our educational events by sparking kids' interest in their surroundings. Focusing on “Time,” “Space,” and “Community,” we'll dive into a mix of hands-on experiences, deep thinking, and creative making. Join us as we explore the many different faces of cities and the future.

Location: Taoyuan Children's Art Center
Sign Up



Official Website

Community: “My Green Neighbours” Workshop

 5/4 (Sat), 5/18 (Sat)

 14:00-16:00

In the city, we often see houses and people, but in city green spaces, a variety of animals and plants live alongside us. Ever wonder why they're here in the city? This workshop, based around Chintan Park, let us dive into urban ecology and creative collecting. We'll discuss how we can live together with these animals and plants, making sure they, too, have a comfortable home in the city.

Time: “This Second in the City” Workshop

 6/1 (Sat), 6/15 (Sat)

 14:00-16:00

Join us for a family photography adventure around the Taoyuan Children's Art Center and Chintan Park. Observe the life around us and capture “This Second in the City” - a snapshot of our lives and the moments that move us.

Space: “Future City Planner” Workshop

 7/6 (Sat), 7/20 (Sat)

 14:00-16:00

What does a future city look like for you? Low-rise buildings or towering skyscrapers? Filled with high-tech in every corner or a return to simple, human-centered living? If you were planning the city of the future, how would you design it?

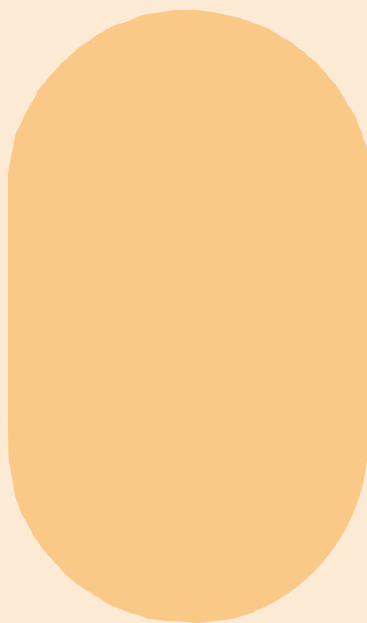

“Arrival Cities”

Education Promotional Event

Culture, ecology, and ethnic diversity weave together the multifaceted urban landscape of Taoyuan. Following the unique perspective and solid footsteps of artists, let's make new friends, discover different versions of ourselves, and uncover the various stories within the city.

Location: Taoyuan Children's Art Center (Bade)

Sign Up



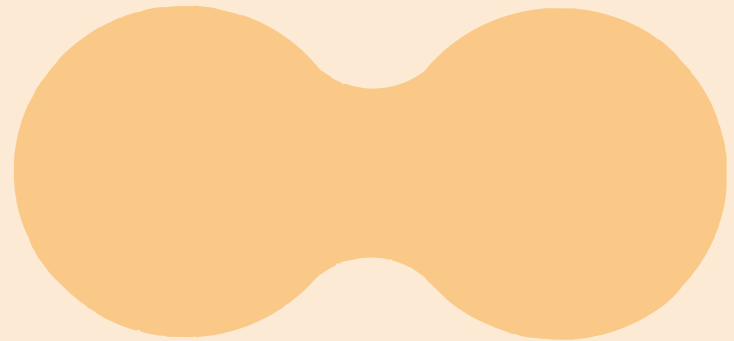

Official Website



Artist Workshops

Walking Tour - Lu Chien-Ming

 5/11 (Sat), 5/25 (Sat)

 14:00-16:00

Incense Journey: From Southeast Asia to Taiwan - Taoyuan City Southeast Asian Art and Education Innovation and Research Association (SEAMi SouthEast Asian Migrant inspired)

 6/8 (Sat), 6/22 (Sat)

 14:00-16:00

Map - Wang Hsiu-Ju

 7/13 (Sat), 7/27 (Sat)

 14:00-16:00

Textile -Alie Tamapima

 8/10 (Sat), 8/24 (Sat)

 14:00-16:00

2024 International Symposium on Children's Education in the Art Museum

"Designing Exhibitions for Children - 2024 International Symposium on Children's Education in the Art Museum" is hosted by Professor Wu Dai-Rong as the guest organizer. This forum convenes experts and practitioners from around the globe to focus on the theme of contemporary art exhibitions for children. It endeavors to delve into an array of curatorial theories and hands-on approaches, aspiring to foster a rich dialogue that could illuminate broader perspectives and innovative avenues for curating children's exhibitions.



Official Website

The symposium will encompass the following key themes, complemented by two panel discussions:

Theme 1: Exploring Children's Curatorial Work from the Center's Vantage Point

Theme 2: Local and Diverse Implementations of Children's Curatorial Projects

Theme 3: Transitioning from Curating for Children to Facilitating Children as Curators

Theme 4: Developing a Methodology for Children's Curatorial Practice

Panel Discussion I: Interdisciplinary Insights into Curating for Children

Panel Discussion II: Utilizing Museum Spaces as Implicit Educators



Date: 5/30 (Thur) – 5/31 (Fri)



Location: Taoyuan Children's Art Center (International Auditorium)



Online Registration

Museum-School Collaboration

In anticipation of the 2024 inaugural trial operation of the Taoyuan Children's Art Center, a pioneering collaboration with Qing Pu Elementary School is set to take place. This partnership aligns with the new curriculum guidelines, embracing interdisciplinary and diverse learning concepts and focusing on the community and students' perspectives. Artist Cheng Wan-Chien explores the Qingpu area through sound, creating and developing educational materials. This initiative aims to foster the accumulation of local knowledge and the formulation of communal visions, ultimately broadening the access to cultural welfare for all.



Official Website

Museum-School Collaboration Presentation



Date: 6/5 (Wed)



Time: 11:00-17:00



Location: Taoyuan Children's Art Center (International Auditorium)

This event will provide professional development hours for teachers.

This program is open to school teachers' groups, please go our website for registration.

ArtFest Kids Market

Throughout four consecutive weekends in April, a series of exciting events are assembled under distinctive themes and featuring collaborations with various artists. This includes an array of art workshops for both kids and adults, pop-up interactive performances, and exciting obstacle courses, along with a diverse marketplace boasting art displays and tasty delights. Children are invited to unleash their creative imagination and learn more about themselves through the art-making process, creating a diverse and experiential children's art market.





Children's Adventure: 4/4 (Thur) - 4/7 (Sun)

Natural Living: 4/13 (Sat) - 4/14 (Sun)

The Future of Art: 4/20 (Sat) - 4/21 (Sun)

Love and Family: 4/27 (Sat) - 4/28 (Sun)

 Time: 11:00-17:00

 Location: Taoyuan Children's Art Center (Art Street, Outdoor Pavement)

Our House: 2024 World Book Day Themed Book Exhibition at the Taoyuan Children's Art Center

The Taoyuan Children's Art Center joyously announces the opening of its new premises! Situated in the serene Chintan Park, the center's architecture, inspired by the form of a hill, represents a collaborative masterpiece by esteemed architects from Taiwan and Japan, marking a prominent feature in the Qingpu landscape. Coinciding with this year's World Book Day and the inauguration of the new facility, the 3rd-floor Children's Art Library presents "Our House: 2024 World Book Day Themed Book Exhibition at the Taoyuan Children's Art Center." A selection of 30 exceptional picture books themed around architecture invites visitors to wander through architectural wonders across six different themes, hoping that all visitors can enjoy reading and appreciate the beauty of architecture and picture books in the center's new site.

"Our House" Themed Book Exhibition



4/19 (Fri) - 6/30 (Sun)



Taoyuan Children's Art Center (Outside the 3rd-floor Children's Art Library Space)

World Book Day Themed Talks and Workshop Activities



4/20 (Sat), 4/21 (Sun)



Taoyuan Children's Art Center

Event information and registration link



Container City

Imagine a city as a huge, enchanting treasure box where many different people, plants, and animals live together.

What stories are hidden inside the Container City?

How do newcomers get to know this place? How do the original residents welcome new friends? In Container City, there's a small city made of tracks, as well as urban graffiti.

Everyone is welcome to explore and play together in Container City.

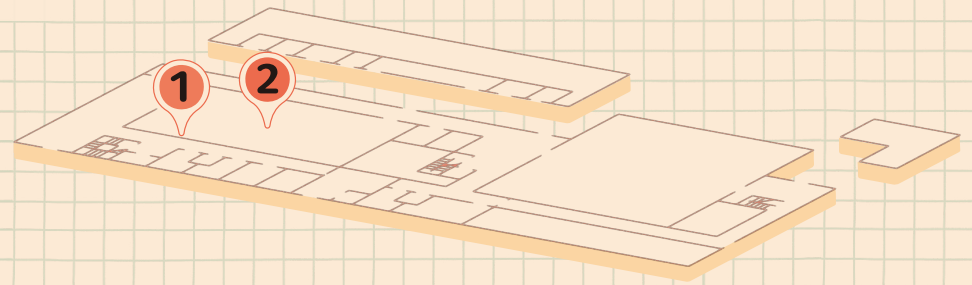

Venue: Taoyuan Children's Art Center 1F

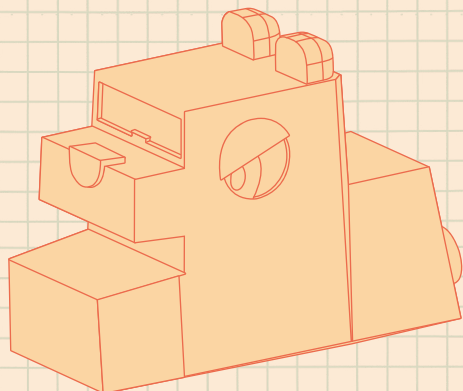
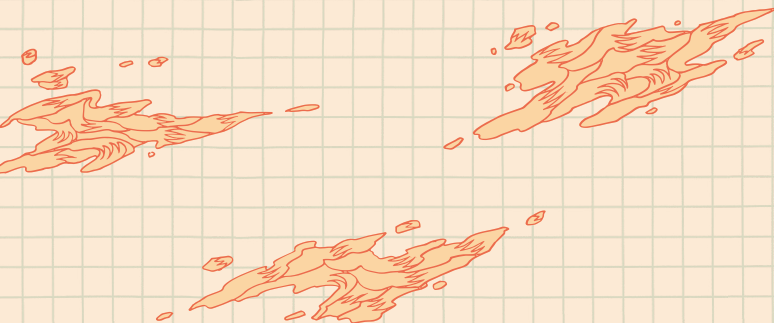

1 REACH, *CITY MAP*

You'll find familiar street art and big color blocks that remind us of the ponds we know well. Streets and ponds, two very different views, blend into our lives and pop out in the artwork that the artist create.

2 Lee Wen-Cheng, *Good Neighbour*

Imagine becoming the main characters in a game, hunting for presents, meeting neighborhood friends, and zooming around in little cars across the city. Let's visit our neighbors together!

Map City

What if you had a map showing every detail of the city - houses, parks, streets, even airports? It could take you to places you want to see and even to spots that aren't there anymore, like a secret base in the old house where dad used to play, hopscotch drawn by mom on the temple grounds, or a vanished railway. With this map, you can travel from the past to the present and even into the future. Where would you like to go? Welcome to Map City.

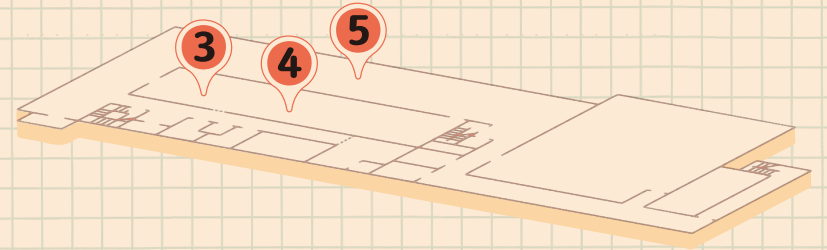

Venue: Taoyuan Children's Art Center 2F

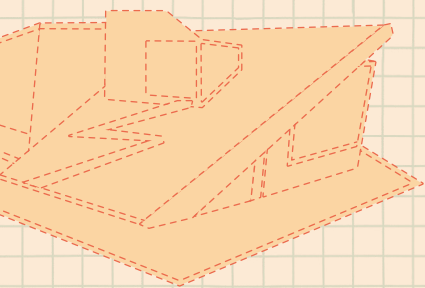

3 Deng Wen-Jen, *Qingpu Time Travel*

The artist uses delicate hand embroidery and machine sewing to create maps full of Qingpu history and tales, guiding us through a hundred years of Qingpu's past.

4 Chiu Chieh-Sen, *Time Map*

We collected coal, small rocks, and maps from the railways and stored them in a treasure cabinet on the wall. It helps us remember the beautiful scenes we used to see from the train windows, bringing back forgotten memories of the Taoyuan-Linkou Railway.

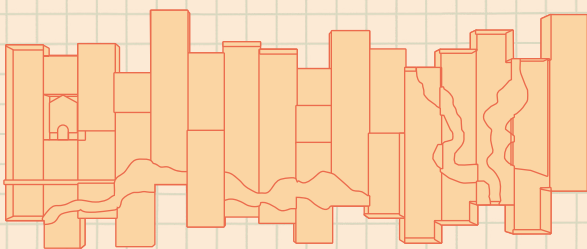

5 Tuan Tsun-Chen, *Traces of the City*

Down a winding path, a ball rolls along, going through arch after arch. As we push the ball, we bend, twist, and reach out, turning into the city's busiest visitors.

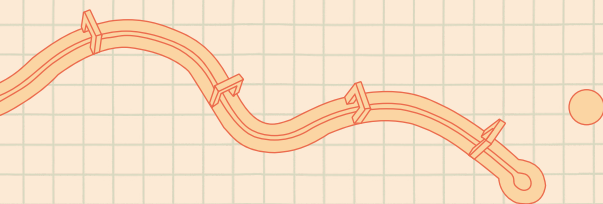

Nature City

Imagine we're flying high in a plane. Looking down, the sunlight makes the ponds shimmer, like bright, watery eyes. Streams and large irrigation channels crisscross the city. Taoyuan Children's Art Center in Chintan Park, resembling a hill and surrounded by nature, features artificial mountains and hills, channels echoing the sound of water, and playgrounds transformed from seeds, welcoming you to nature within the city.

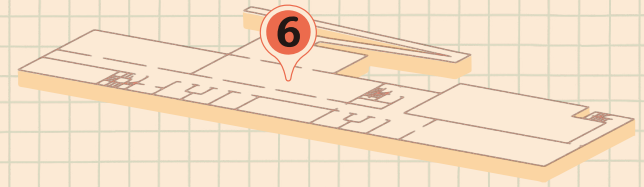

Venue: Taoyuan Children's Art Center 3F

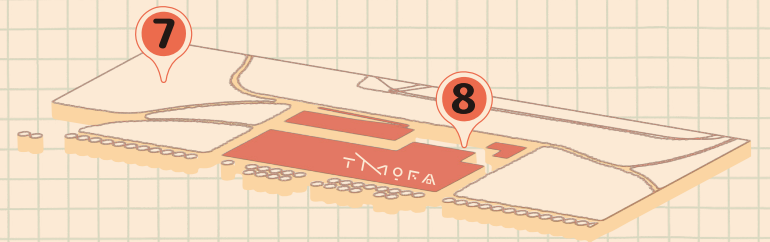

Venue: Taoyuan Children's Art Center 1F Outdoor

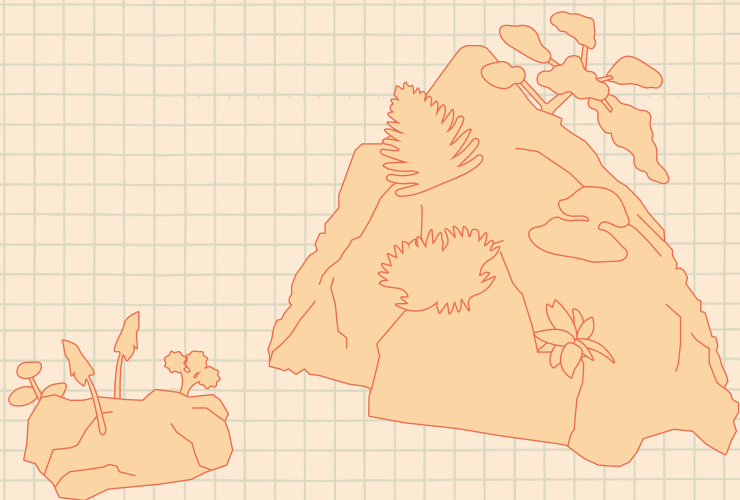
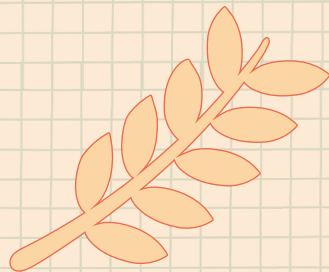
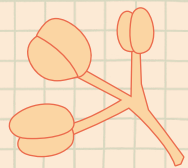

6 Sandwiches Studio, *Seed City*

People from all over the world arrive in this city, bringing all kinds of plants. These plants are turned into every kind of pillow you can imagine, letting kids lay down, pile them up, and hug the colorful softness.

7 Tsai Kuen-Lin, *Three Mountains, Three Rivers*

Standing quietly, its shape twists and turns like mountain peaks and rivers, almost like a tiny version of nature.

8 Liu Wen-Chi, *We Meet Slowly in the Forest: Run! Distant Wild Hills*

If you're tired from running, feel free to sit down, sip some water, and soak up the sun. If you're feeling down, just gaze at the distant wild hills. Any troubles you can't figure out seem to get better.

The Rock That Grew a Door

Artist: ENESS

Date: 3rd April – 1th September, 2024

Exhibition Description

The Taoyuan Children's Art Center (TCAC) presents The Rock That Grew a Door, an ENESS exhibition at its open-air platform. The exhibition features the eponymous site-specific interactive installation that invites both children and adults to play and enjoy an experience of imagination and wisdom.

Note

Online reservation required. To reserve, please visit the TCAC website. In case of adverse weather, TCAC reserves the right to adjust the opening statues of the exhibition.

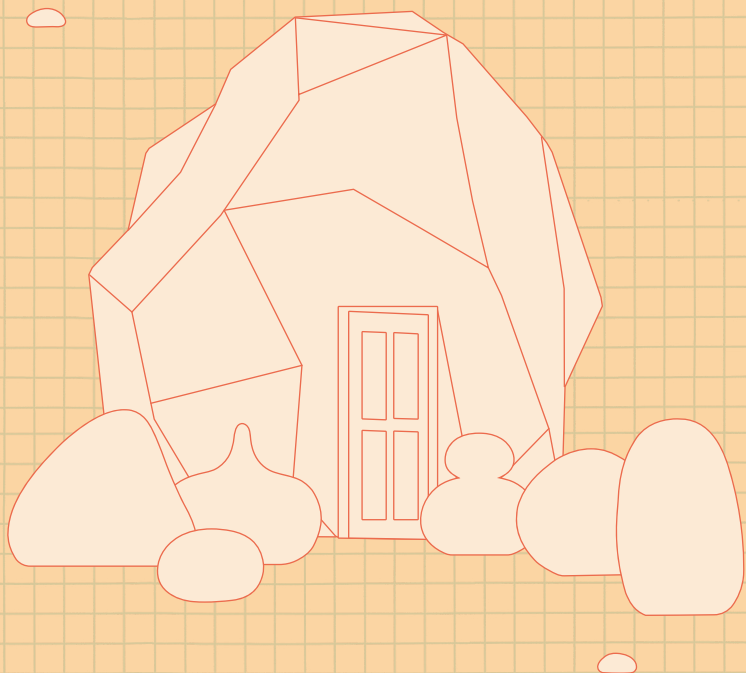

Venue: Taoyuan Children's Art Center (4th floor)

9 Artwork Story

This rock is different. It has a door. The Rock That Grew a Door, grew a door because now, after billions of years, he wants to let you in. But he will only let you in if you put in enough work communicating in rocky ways and working hard to discover his secrets. If you spend time with his baby rocks, he will open the door to rock wisdom from around the world.

Arrival Cities:

Where Are You From, My Friend?

The place where we live is surrounded by factories, with tall buildings built on the edge of fields. People from different ethnic groups have come from the mountains, from the sea, and even from different countries to live together. In the cities we moved to, we learn to build houses, and those who were once encircled by mountains weave green forests in the city, drawing maps of their hometowns from memory and returning to the homes they miss through songs and smells.

Where do you come from, my friend? Welcome to Arrival Cities.

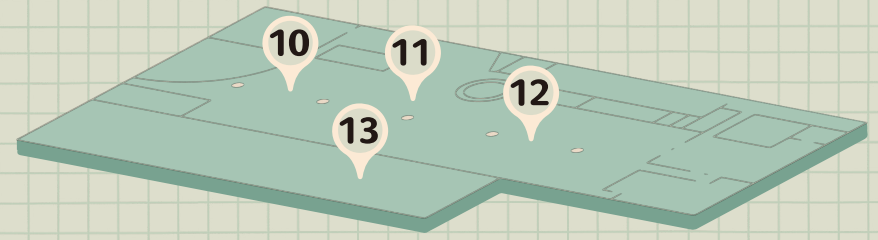

Venue: Taoyuan Children's Art Center (Bade)

10 Chien Tzu-Lun, *This is My Home*

Soft cushions carry the scent of familiar spices, as well as songs from Indonesia, Vietnam, and Thailand that mom used to sing. This is my home, a place of comfort surrounded by scents and songs.

11 Alie Tamapima, *Half and Half*

Being half indigenous and half from the plains, I often feel that I don't belong to any particular group. I move along with the times and the mixing of cultures: "I am half and half."

12 Wang Hsiu-Ju, *Little Worlds*

My parents moved to the city for work, while my grandparents still live in the far-off mountains, by the sea. Whether it's the crowded city or the vast wilderness, both are my little worlds, my cozy corners.

13 Lu Chien-Ming, *Beneath the Wing*

Imagine a giant bird's nest, as fluffy as chicken feathers. We play, rest, and chat under its protective wings, all while the sweet smell of rice drifts around us. This house, built together by artists and students, invites you into its embrace, a hidden fort inside the center.

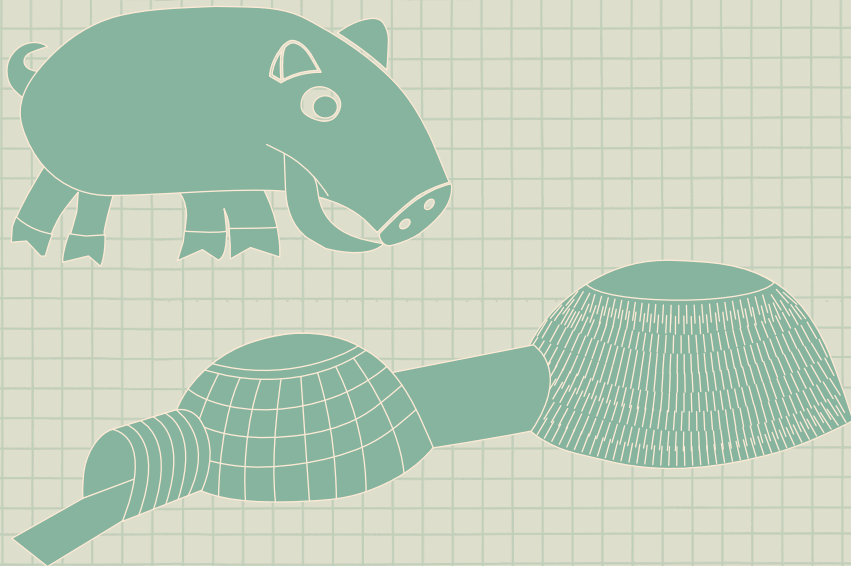

Where the Adventure Begins! Taoyuan Children's Art Center Inaugural Exhibition

2024/4/3-2024/9/1

Taoyuan Children's Art Center 1F, 2F, 3F

The Rock That Grew a Door

2024/4/3-2024/9/1

Taoyuan Children's Art Center 4F

Taoyuan Children's Art Center

No. 90, Sec. 2, Gaotie S. Rd., Zhongli Dist., Taoyuan City

Open Wednesday to Monday 09:30-17:00

(Closed on Tuesdays)

Arrival Cities: Where Are You From, My Friend?

2024/4/30-2024/9/8

Taoyuan Children's Art Center (Bade)

5F., No. 728, Sec. 1, Jieshou Rd., Bade Dist., Taoyuan City

Open Tuesday to Sunday 09:30-17:00

(Closed on Mondays and Public Holidays)

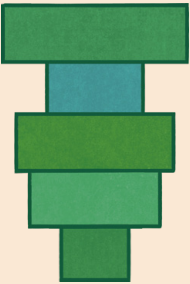

Participating Artists

Container City: REACH, Lee Wen-Cheng

Map City: Chiu Chieh-Sen, Tuan Tsun-Chen, Deng Wen-Jen

Nature City: Sandwiches Studio, Liu Wen-Chi, Tsai Kuen-Lin

Arrival Cities (Taoyuan Children's Art Center, Bade): Alie Tamapima, Chien Tzu-Lun, Lu Chien-Ming, Wang Hsiu-Ju

Organizer :

Taoyuan Museum of Fine Arts, Taoyuan Children's Art Center

Supervisor :

Ministry of Culture, Taoyuan City Government, Taoyuan City

Council, Department of Cultural Affairs, Taoyuan



Official Website